

# INDUSTRIAL TUMBLE DRYER

**T**  
RANGE

T 11	T 13	T 13/13	T 16
11KG 24LB	13KG 20LB	2X13KG 2X27LB	16KG 35LB



## FEATURES

- Standard stainless steel drum with large diameter
- Easy-to-use microprocessor (ECT)
- Combination of Radial and Axial airflow - RADAX® concept:
  - maximal heat transfer
  - low energy consumption
  - short drying time
- Large door opening for easy loading and unloading
- Self cleaning lint screen

## OPTIONS

- Connectivity with i-Trace Solution via WiFi Kit accessory
- Coin operated version
- Reversing drum
- Full Control programmer (FCT)
- Residual moisture control Sensodry®:
  - safe drying of delicate linen
  - humidity detection in %
  - ideal in combination with SoftWash®
  - ideal for dry cleaners, fire depts
  - available on Easy and Full Control
- Stainless steel front

T 13/13

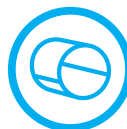

STANDARD  
STAINLESS STEEL  
DRUM



LARGE DOOR  
OPENING



ENERGY  
EFFICIENT



**GET AHEAD** IN LAUNDRY

TYPE		T11	T13	T13/13	T16
<b>CAPACITY</b>					
Drum capacity 1:18	kg/lb	12/26	16/35	2x16/2x35	19/42
Drum capacity 1:22	kg/lb	11/24	13/29	2x13/2x29	16/35
Drum volume	l	250	285	2x285	345
Drum diameter	mm	Ø 760	Ø 760	2xØ 760	Ø 760
Number of drums		1	1	2	1
Number of loading doors		1	1	2	1
<b>AIRFLOW</b>	m <sup>3</sup> /h	520	550	1050	600
<b>DRYING AVERAGE</b>	l/min.	190	225	2x225	300
<b>MOTORS</b>					
Fan	kW	0,55	0,55	2x0,75	0,55
Drive	kW	0,25	0,25	2x0,25	0,25
<b>GAS HEATING</b>					
Gas connection	NPT	1/2"	1/2"	2x1/2"	1/2"
Electrical connection			3x220-240V 50Hz, 1x220-240V 50Hz, 3x380-415V 50Hz		
Energy	kW	16,5	19,5	2x19,5	25
	kBTU/h	56,3	66,5	2x66,5	85,3
<b>STEAM HEATING</b>					
Steam connection	NPT	3/4"	3/4"	3/4"	3/4"
Electrical connection			3x220-240V 50Hz 1x220-240V 50Hz 3x380-415V 50Hz		
Steam output *	kW	16,5-22	19,5-27	2x19,5-27	22-32
Steam pressure	bar	3-6/7-10	3-6/7-10	3-6/7-10	3-6/7-10
<b>ELECTRICAL HEATING</b>					
Electrical connection			3x220-240V 50Hz, 3x380-415V 50Hz, 3x480V 60Hz		
Energy	kW	13,5	18,0	2x18,0	24,0
<b>PROGRAMMER</b>					
Easy control - antivandal (ECT)		Standard	Standard	Standard	Standard
Full control (FCT)		Available	Available	Available	Available
<b>EXHAUST</b>	mm	200			
<b>DIMENSIONS</b>					
H×W×D	mm	1680x795x1070	1680x795x1160	2030x795x1240	1680x795x1280
Net weight	kg	230	250	370	250
<b>TRANSPORT DATA</b>					
Packed H×W×D	mm	1785x855x1100	1785x855x1190	2120x880x1325	1785x855x1310
Gross weight	kg	240	265	385	270

\* Steam output is flexible depending on steam pressure, The data concerning dimensions of machines include all extended parts

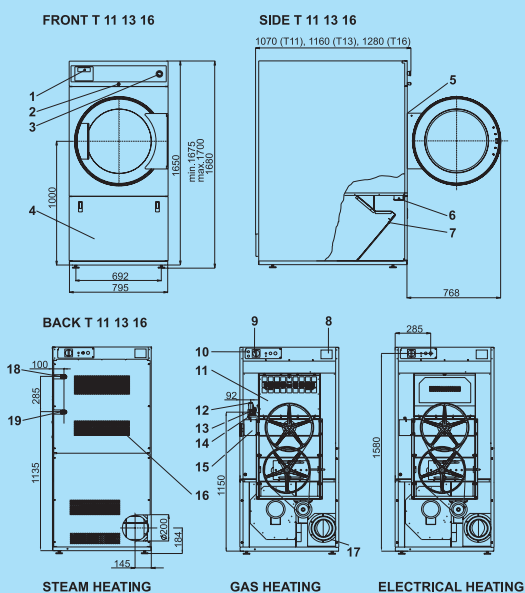

1. Programmer
2. Lock of the control panel
3. Emergency stop button (not applicable for version with coin meter)
4. Lint screen cover
5. Door lock microswitch
6. Lint cover microswitch
7. Lint screen
8. Name plate
9. Main switch
10. Main power supply
11. Heating chamber
12. Gas valve (G models only)
13. Pressure regulator (G models only)
14. Gas supply (G models only)
15. Airflow switch
16. Suction
17. Exhaust piping
18. Steam supply
19. Condense drain