



SPEED QUEEN | PROFESSIONAL

Stacked Washers and Dryers for OPL

STW (Washer & Dryer)

STD (Dryer & Dryer)

Get the most out of the Speed Queen legendary performance on a reduced floor space thanks to our stack washer-dryers or dryer-dryer. Totally free-standing, they can be installed on any floor and any level. They are available with top and front panels in anthracite grey or stainless steel.

Best-in-class Quantum® Gold Controls

Revolutionary Quantum® Gold technology combines equipment controls, programming and wireless networking into one full-OPL management system, including: wireless networking, adjustable water levels and in-depth reporting. Designed to reduce costs and maximize revenue, Quantum gives you the power to achieve unprecedented levels of profitability.

Features Washer Extractors

- Stainless steel outer and inner drum
- Industry-leading 440 G-Force extraction removes more moisture, minimizing drying times and utility costs
- Suspension with new out-of-balance logic
- Soap box with four compartments
- Available with drain pump or drain valve
- Electrical heating or boiler-fed
- Soap supply injection allows easy connection with liquid soap pumps
- Longer lifetime: at least 15,000 cycles

Features dryers

- Galvanized steel cylinder
- Oversized lint filter located in front for easy cleaning
- Powerful exhaust blower assures short drying times and low operating costs
- Electrical or gas heating

Quantum Controls

- 4 drying programs



Quantum Controls

- 6 programs
- 3 cycle modifiers



Fast cycles



Large Door Opening



Low Water Consumption



Low Energy Consumption



Standard Stainless Steel Drum



Compact Design

Connectivity

Wi-fi connectivity via accessory, enabling access to Speed Queen Insights and Speed Queen App.

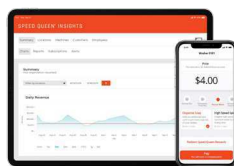

Stacked Washer & Dryer

Specifications



STW							
	MARKET	ACTUATION	HEATING	VOLTAGE	CONTROL LOCATION	COLOR	DRAIN
ST2JGASP403UN01	Europe/CE	OPL ¹ / PCP ²	Electric W-Gas D	400v/50Hz/3N	10° front control	Stainless	Pump
ST2JGASP403UG01	Europe/CE	OPL ¹ / PCP ²	Electric W-Gas D	400v/50Hz/3N	10° front control	Grey	Pump
ST3JGASP403UN01	Europe/CE	OPL ¹ / PCP ²	3ph W,3ph D	400v/50Hz/3N	10° front control	Stainless	Pump
ST3JGASP403UG01	Europe/CE	OPL ¹ / PCP ²	3ph W,3ph D	400v/50Hz/3N	10° front control	Stainless	Pump
ST3JGJAP403UG43 ³	Europe/CE	OPL ¹ / PCP ²	3ph W,3ph D	400v/50Hz/3N	10° front control	Grey	Pump
ST3JGASG403UG01	Europe/CE	OPL ¹ / PCP ²	3ph W,3ph D	400v/50Hz/3N	10° front control	Grey	Gravity drain
ST3JGASP403NG22	No Agency	OPL ¹ / PCP ²	3ph W,3ph D	400v/50Hz/3N	10° front control	Grey	Pump

¹ OPL On Premise Laundry

² Prep for Central Pay

³ Soap Supply System

Washer Extractor		
CAPACITY	kg	9,5
Capacity Ratio 1:9	kg	10,5
TYPE OF CONTROL		Quantum
DRUM VOLUME	l	96,8
BASKET		Stainless Steel
MOTOR		
Frequency controlled	kW	0,67
EXTRACTION SPEED	rpm	1200
G-FACTOR		440
ELECTRICAL HEATING		
Electrical	kW	4,8
Dryer		
CAPACITY	kg	8,2
Capacity Ratio 1:19	kg	10,5
TYPE OF CONTROL		Quantum
DRUM VOLUME	l	198
BASKET		Galvanized
ELECTRICAL HEATING	kW	5,2 (230V) 5,3 (400V)
GAS HEATING	kW	7,3
MOTOR POWER	kW	0,25

Stacked Washer & Dryer		
DIMENSIONS H×W×D	mm	1986×683×704
Net weight	kg	177
TRANSPORT DATA		
Volume (packed)	m ³	1,25
Packed H×W×D	mm	2032×760×860
Gross weight	kg	193

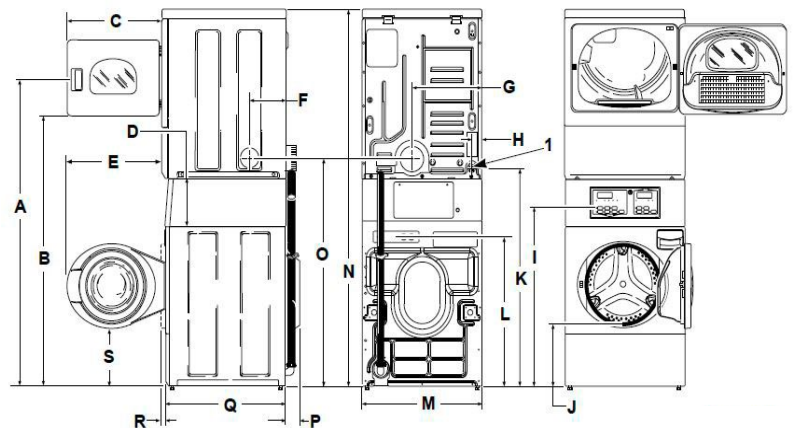

	A	B	C	D	E	F	G	H	I	J	K	L	M	N	O	P	Q	R	S
mm	1678	1447	597	213	610	203	391	59	938	371	1140	813	683	1986	1184	52	704	38	333



Stacked Dryer & Dryer

Specifications

	STD							
	MARKET	ACTUATION	HEATING	VOLTAGE	CONTROL LOCATION	COLOR	BASKET	DRAIN
SSGNGAGS303UG01	Europe/CE	OPL ¹ / PCP ²	Gas	230v/50Hz/1N	10° front control	Grey	Galvanized	Solid
SS3NGAGS403UG01	Europe/CE	OPL ¹ / PCP ²	Electric	400v/50Hz/3N	10° front control	Grey	Galvanized	Solid

¹ OPL On Premise Laundry

² Prep for Central Pay

		Dryer
DRUM VOLUME	l	198
CAPACITY	kg	8,2
Capacity Ratio 1:19	kg	10,5
MOTOR		
ELECTRICAL HEATING	kW	5,2 (230V) 5,3 (400V)
GAS HEATING	kW	7,3
MOTOR POWER	kW	0,25
TYPE OF CONTROL		Quantum

		Stacked Dryer& Dryer
DIMENSIONS H×W×D	mm	1986x683x711
Net weight	kg	120 (el.) /125 (gas)
TRANSPORT DATA		
Volume (packed)	m ³	1,30
Packed H×W×D	mm	2032×760×860
Gross weight	kg	127 (el.) /132 (gas)

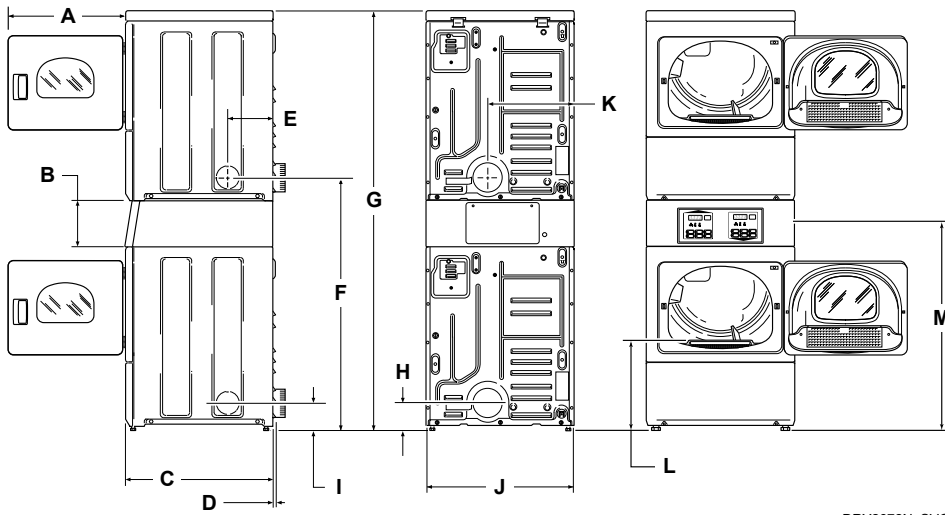

DRY2672N_SVG

	A	B	C	D	E	F	G	H	I	J	K	L	M
mm	597	213	711	11	203	1184	1986	102	114	683	391	392	994

